

METHOD OF STUD

METHODS OF STUDY

The study was planned and executed in phases.

COLLECT AND REVIEW ALL DATA

All available existing information was gathered and examined in detail. Data collection include surface maps, stream data, soil information, coal structure contours, geology, ground water data, available planning information, tax maps, and important historical data.

Liaison and data gathering include agencies such as: Pennsylvania Department of Environmental Resources, The Coal Industry, U. S. Department of Agriculture, Pennsylvania Geological Survey, local sportsman's groups, local citizens, and any other agency that may have pertinent information.

RECONNAISSANCE

An initial field reconnaissance has been made along Big Run, sampling all discharges and tributaries. Thirty-eight field tests were made during the original stream survey.

The field reconnaissance established exact locations of flow measuring and water sampling stations. The stations were marked and permission to enter the property for sampling and/or to construct weirs was obtained where feasible.

The specific locations for weirs and/or stream cross sections were selected to assure the most uniform channel (stream) configuration. Weir widths and types were selected, and the most expeditious sampling and measuring route developed. The specific scope of the sampling and measuring

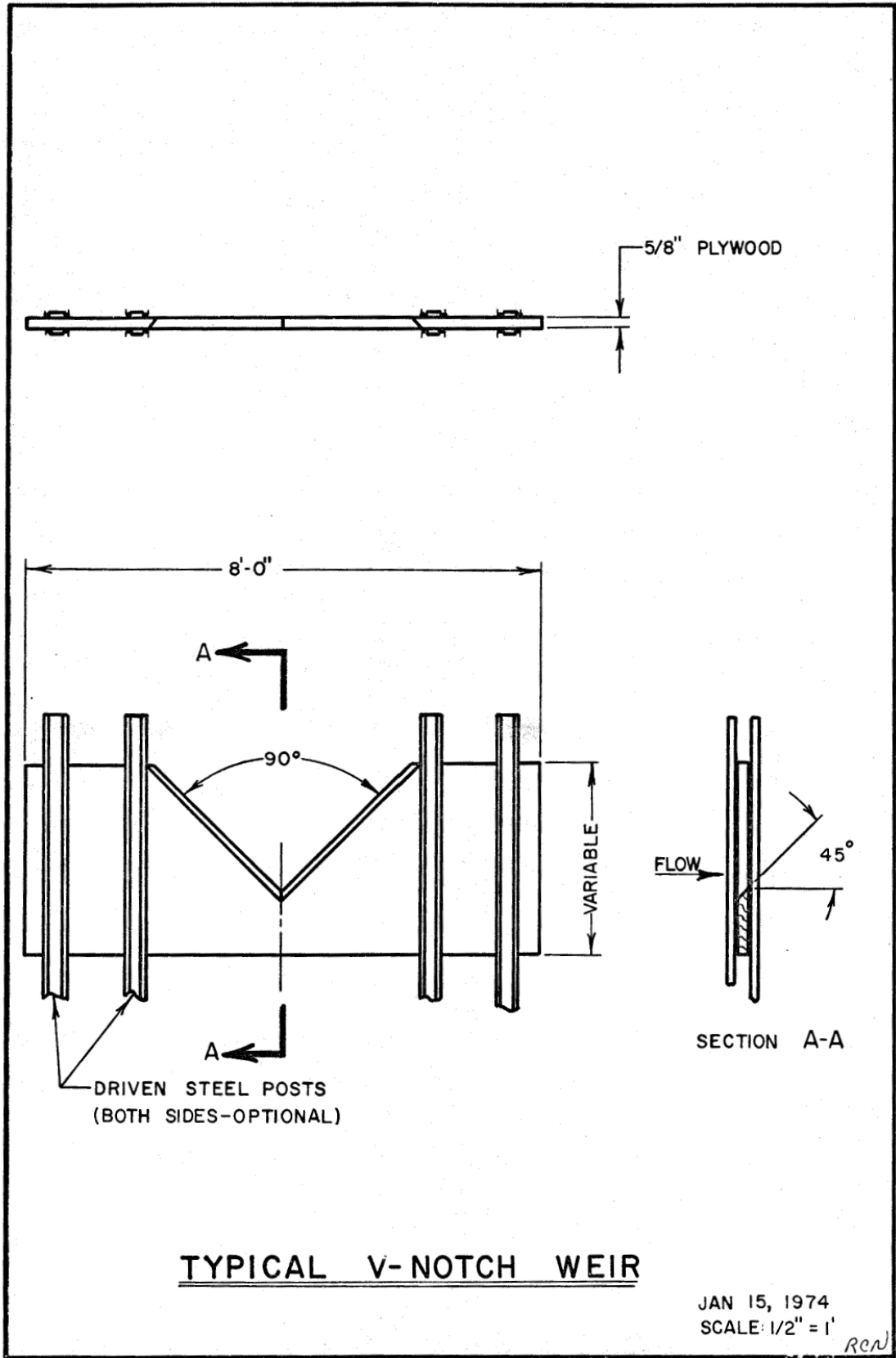

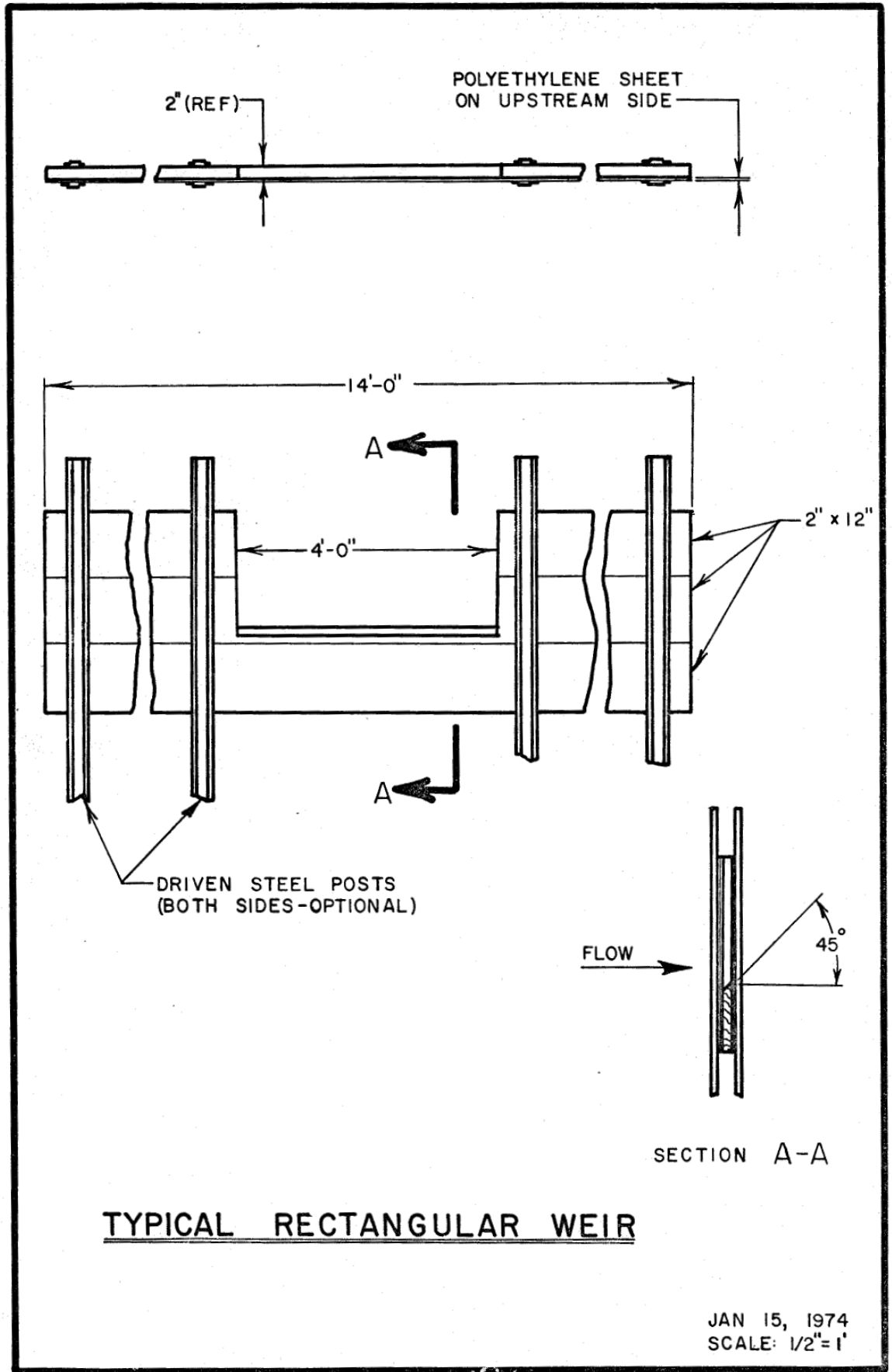

program was established, with the control stations and access routes plotted on watershed maps.

The initial reconnaissance was completed and has revealed many unusual aspects of the watershed which had to be considered for proper direction of the sampling program. Samples were taken and flows estimated at the time of the initial reconnaissance to help guide the study efforts in delineating the major problem areas.

CONTROL SAMPLING

A watershed sampling and measuring study was performed which included the construction of 17 weirs where stream flows were of a size to accommodate economical weir construction. At other locations where weir construction was not feasible, cross sections of the stream were taken, water areas measured, velocities obtained by the "floating chip" method and the flows computed. Any cross sections required were taken at one foot horizontal intervals, plotted on cross section paper and used throughout the course of the study.

Water samples were collected at each station and flow measurements taken on a regular basis. Sampling and measuring were done periodically, with some rounds omitted during periods of extremely high water or hard. freeze over a span of approximately 5 months.

The ultimate goal of this study does not warrant the sophistication usually associated with an academic study. The purpose of this study is to provide sufficiently accurate data to develop conclusions and recommendations for abatement of acid mine drainage and restoration of surface mined lands to a desired level.

Water samples were analyzed for pH, acidity, alkalinity, total iron and sulphates. The results of the chemical analysis were converted to loadings in pounds per day at each sampling station by multiplying the chemical analysis results (ppm) by the computed flows, using the appropriate mathematical conversion factors.

Employees of the Ebensburg District Office, Department of Environmental Resources, with the cooperation of interested local citizens, constructed all weirs. Field explorations and sampling and measuring were accomplished by the employees assigned to the Ebensburg District Office.

DETAILED FIELD EXPLORATIONS

Detailed field explorations were conducted to gather hydrologic and geologic information, to verify previously collected information, and to catalog pollution sources. The field explorations included walking of the stream to account for all sources of water. These explorations also entailed the walking of all known mined lands, both underground and strip, to determine their affect on the watershed and to locate possible drifts, shafts, airways, slopes and caved areas. Detailed descriptions of all pollution sources were logged as discovered. Complete logs of field data are available for use or inspection at any time.

The extent of the stripping operations, both active and abandoned, subsidence areas or other photo interpreted features, as defined from topographic maps, were verified in the field.

In the earliest investigations of Big Run drainage basin, efforts were made to obtain maps of the deep mines. Deep mine maps are available for the Worthville mine, Sprankles Mills mine, King Coal Company mine and St. Marys Sewer Pipe Company mine. The extent of the other deep mines can only be assumed from hearsay and from the size of the mine refuse piles, all of which are quite small. The locations of several deep mine workings cannot be determined because of erosion and vegetative cover.

EVALUATION OF SOURCES AND CORRECTIVE MEASURES

After the location, size, source and physical condition of each polluting discharge was determined, they were individually ranked in terms of pollutorial magnitude, probability of abatement success and cost of feasible pollution abatement measures. The evaluation strived for maximum improvement of Big Run while minimizing costs.

The latest technology in the mine drainage field was considered for use in the abatement plans to be applied to each source of pollution.

Various adaptations and combinations of the following techniques were considered for use in the watershed:

1. Diversion of surface waters around strip mine cuts and deep mine fractures.
2. Rechannelization of water through abandoned strip mines.
3. Terrace backfilling.
4. Soil treatment and planting of strip pits.
5. Sealing deep mine openings.
6. Construction of grout curtains.
7. Exploratory drillholes for determining deep mine workings.